

CARR AMPLIFIERS



OWNER'S MANUAL

Revised 23 February 2012

Sportsman Instructions

Thank you for purchasing a Carr Sportsman amplifier. The Sportsman fuses the insistent purity of '60s American 1x10 reverb-style amps with the more aggressive dual 6V6 power section of the late '50s yielding enhanced sonic span and control. Tones ranging from clear and snappy to Texas pushed twang to intercontinental grind are all under the hood of the Sportsman. Please take time to familiarize yourself with this manual.

Volume – Adjusts the loudness and drive of the amplifier.

Treble – Varies the top end from dark to bright.

Mid – Varies the midrange frequencies and is very interactive with the Treble control. For a '60s American tone, set the Mid to 10 o'clock. The tone becomes more aggressive as you advance the Mid past 1 o'clock. When the Mid is set near full, the Treble control's effect is more subtle.

Bass – Varies the low end from lean to full. To retain clarity, turn the Bass down at higher volumes.

Reverb – Controls the amount of reverb sound from none to deep and lush.

Headroom – The interface between the pre amp and the power amp on the Sportsman. For the cleanest sound, set the Headroom to Max and set the Volume control low. For thicker clean tones, set the Headroom to 11 o'clock and the Volume to 12 o'clock. For overdriven tones, set the Volume to 3 o'clock or higher and set the Headroom to the desired listening level. Higher Headroom settings will bring in more output section overdrive when the Volume is set high.

Standby – Set the amp to Standby (switch baton *down*) before turning on the power switch (see *On-Off-On* below). After 1 minute of warm up, switch the Standby baton *up*. The amp is ready to be played. Using the Standby switch every time the amp is turned on will prolong tube life.

On – Off – On – Selects between two ON positions and the OFF position (middle). The two ON's are wired in opposite phase of each other. If you receive a shock from another piece of equipment (a microphone or another amp) that is not properly grounded, or if you hear static, switching to the opposite ON may solve the problem. This is sometimes called "switching polarity".

Bottom Panel

Fuse – In the unlikely event that a tube fails, the Sportsman is protected by a 1.5 Amp slow blow fuse for 120v and 100v (North America and Japan) models or a 0.75 Amp slow blow fuse for 220v and 240v (Europe and Asia) models. Please consult us or a qualified tech for assistance in the event of a fuse blowing. The fuse is located on the bottom of the chassis by the power cord.

Speaker output jack – The speaker output jack is located between the 3rd and 4th pre amp tubes on the chassis (see *Chassis Diagram*). The Sportsman is designed to drive a 16 ohm load. Maximum power and tone will be realized when connected to a 16 ohm speaker or cabinet. The speakers in Sportsman combos and extension cabinets are configured to provide the amplifier with a 16 ohm load.

The Sportsman will work with an 8 ohm cabinet with the following caveat - you will lose a little power from the impedance mismatch and the power tubes will have to work a bit harder and thus age faster. This effect though is minimal.

To run an external cabinet, turn the Sportsman OFF, unplug the internal speaker (combo amps) and plug in the external cabinet's speaker cord. Alternatively, a "Y" speaker cord can be used to run a 16 ohm external cabinet along with the internal speaker(s) of a combo amp without damage to the amp (the total impedance or speaker load in this case will be 8 ohms – see the previous paragraph).

























Damage will result from operating the Sportsman without a speaker load.

Biasing your Sportsman

The Sportsman utilizes a mix of cathode bias (self bias) and fixed bias and as such does not require a bias adjustment when changing tubes. Please use well-matched pairs of output tubes for maximum performance. The Sportsman can only use matched pairs of 6V6 power tubes.

Carr Amplifiers selects and tests the finest current production tubes specifically for each amplifier model. Caution should be used when buying replacement tubes from any dealer who does not have a return policy as all tubes can have problems (NOS tubes are susceptible to microphonics and failure too).

Recommended Settings

Sound	Volume	Treble	Middle	Bass	Reverb	Headroom
60s American Clean						
Thick BF						
Low Volume Grind						
Texas Overdrive						



CARR AMPLIFIERS CHASSIS DIAGRAM

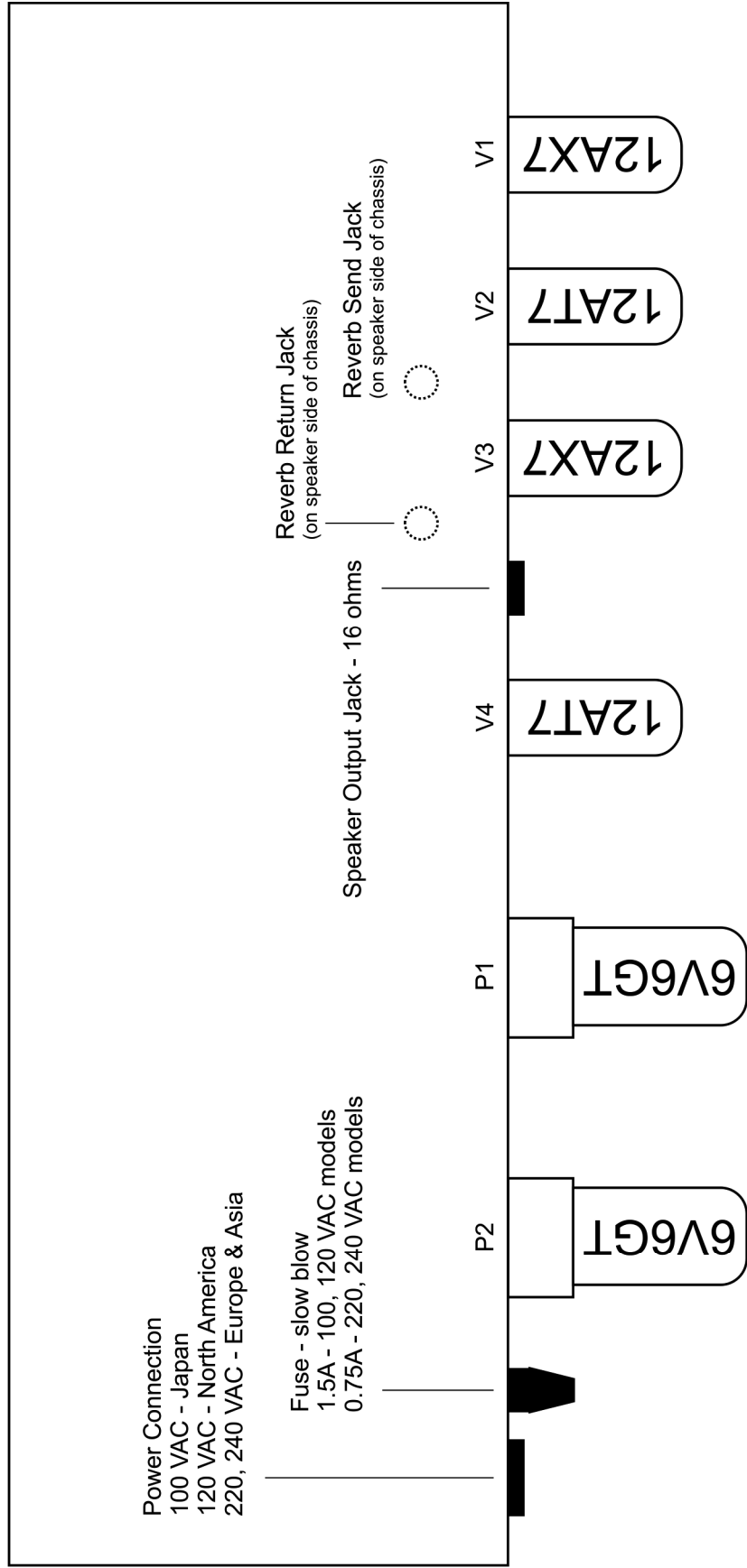

IMPORTANT REMINDERS

- Please keep the original packing materials in case your amp needs to be shipped for service.
- When inserting power tubes, the power tube key must line up with the tube socket keyway.
- When inserting preamp tubes, the tube pins must line up with the tube socket holes.

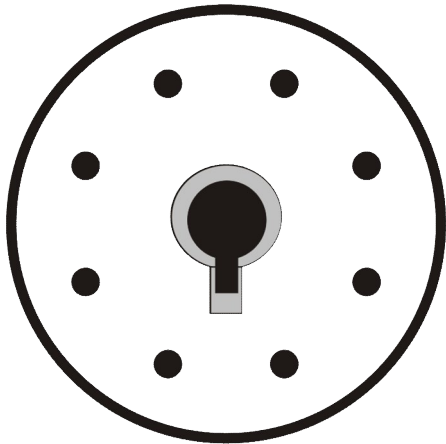

Do not insert power tubes with missing or damaged keys or pins.

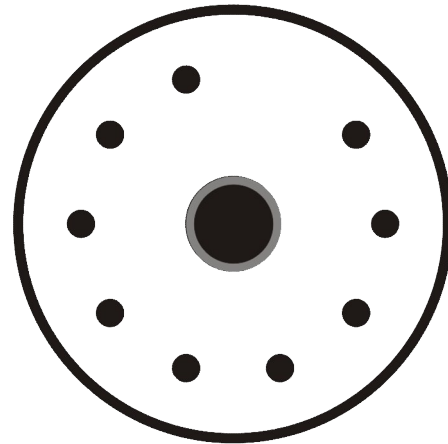

Do not insert preamp tubes with missing or damaged pins.

- To reduce the risk of electric shock, keep the unit away from excess moisture.
- No user serviceable parts inside.
- Potentially lethal voltage present.

CARR AMPLIFIERS WARRANTY

All Carr amplifiers are warranted to be free from defects in workmanship (solder joints, hardware assembly etc.) for the lifetime of the original owner, and free from defects in materials (including cabinet) for three years from the date of purchase by the original owner, provided that:

- The owner mails the signed warranty registration card (next page) and a copy of the original sales receipt to Carr Amplifiers within thirty days of purchase.
- Problems are not the result of misuse, abuse, tampering, circuit modification, improper tube installation (incorrect orientation of tubes can damage the amp), or spilled beverages, as these will void the warranty.
- The amplifier is shipped to Carr Amplifiers in the original packing materials with freight paid by the purchaser. We pay the return shipping after the warranty work is complete.

Tubes, speaker(s), and reverb tanks carry a ninety-day warranty, and are subject to the same terms and conditions as above.

Please call us at 919-545-0747 if you have a warranty claim. Be prepared to provide the model and serial number of your amp. We will issue a Return Merchandise Authorization number (RMA#) before the amplifier is shipped for service.

For customers outside of North America, warranty and repair service is provided through the dealer where the amp was purchased.

Shipping address:

Carr Amplifiers
23 Rectory St., Suite E
Pittsboro, NC 27312

Mailing address:

Carr Amplifiers
433 W. Salisbury St.
Pittsboro, NC 27312

Tel: 919-545-0747

Fax: 919-545-0739

www.carramps.com
info@carramps.com